

serie **307**

Motocoltivatori

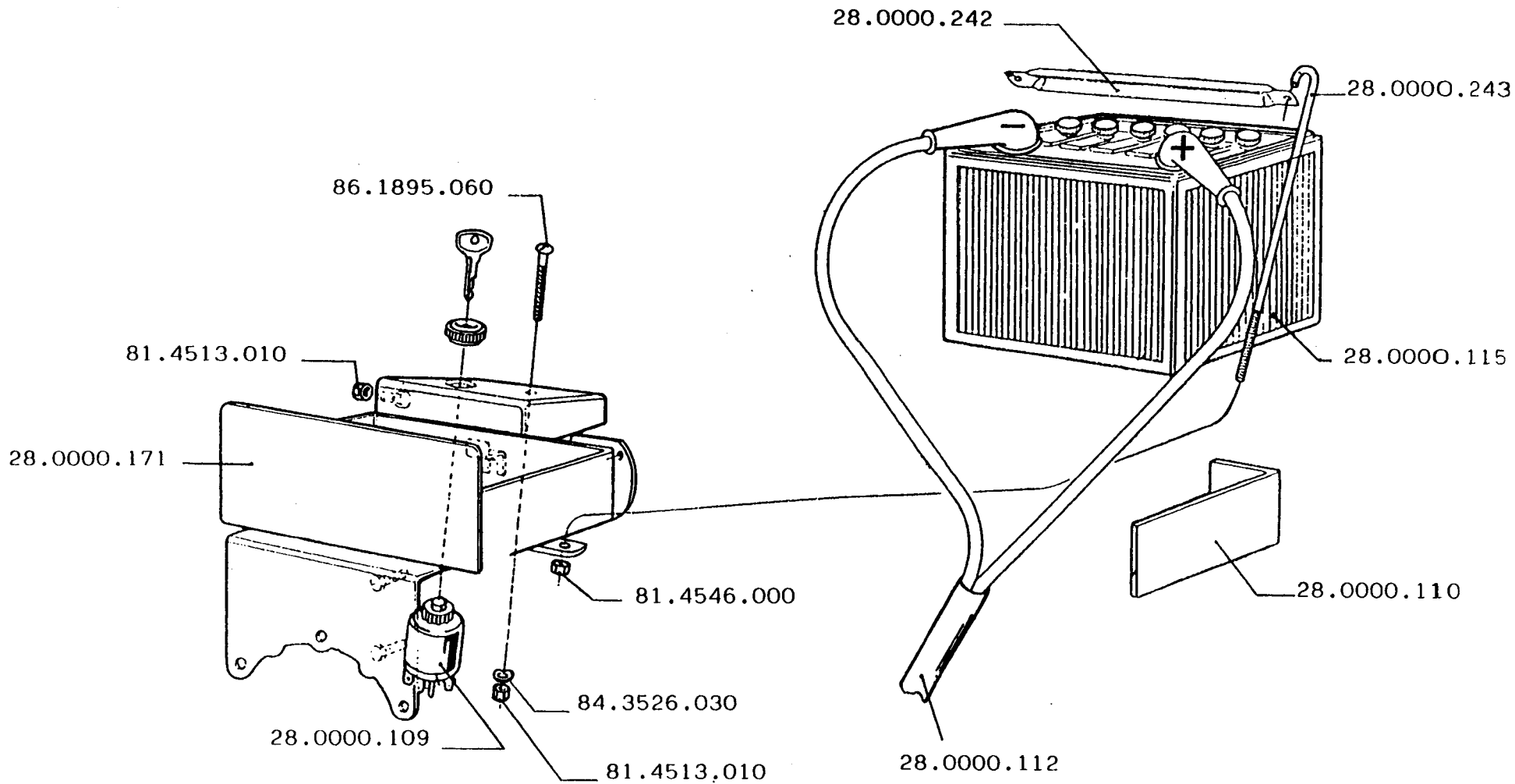

div. della BCS SpA - Viale Mazzini, 161 - 20081 ABBIATEGRASSO - MI - Italia



FERRARI

307

AVVIAMENTO ELETTRICO
 SISTEMA ELECTRICO
 ELECTRIC STARTER

ARRANQUE ELECTRICO
 DEMARRAGE ELECTRIQUE
 ELEKTROSTART

PAGINA
01.00
 DATA

28.0000.020
(6LD 400)

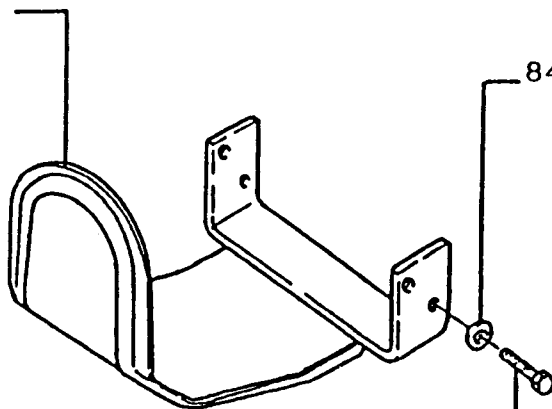

84.3654.000

86.2488.000

84.3654.000

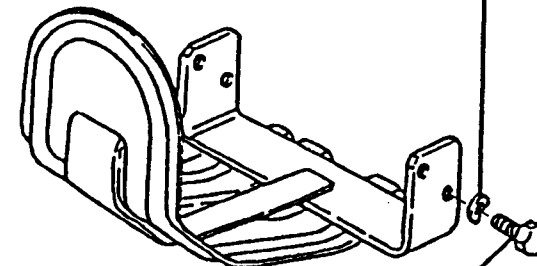

86.2488.000

28.0000.022
(1IM350)



FERRARI

307

SUPPORTI MOTORE
SUPPORTE DO MOTOR
ENGINE SUPPORT

SOPORTE MOTOR
SUPPORT MOTEUR
MOTOREINBAU

PAGINA
02.00
DATA

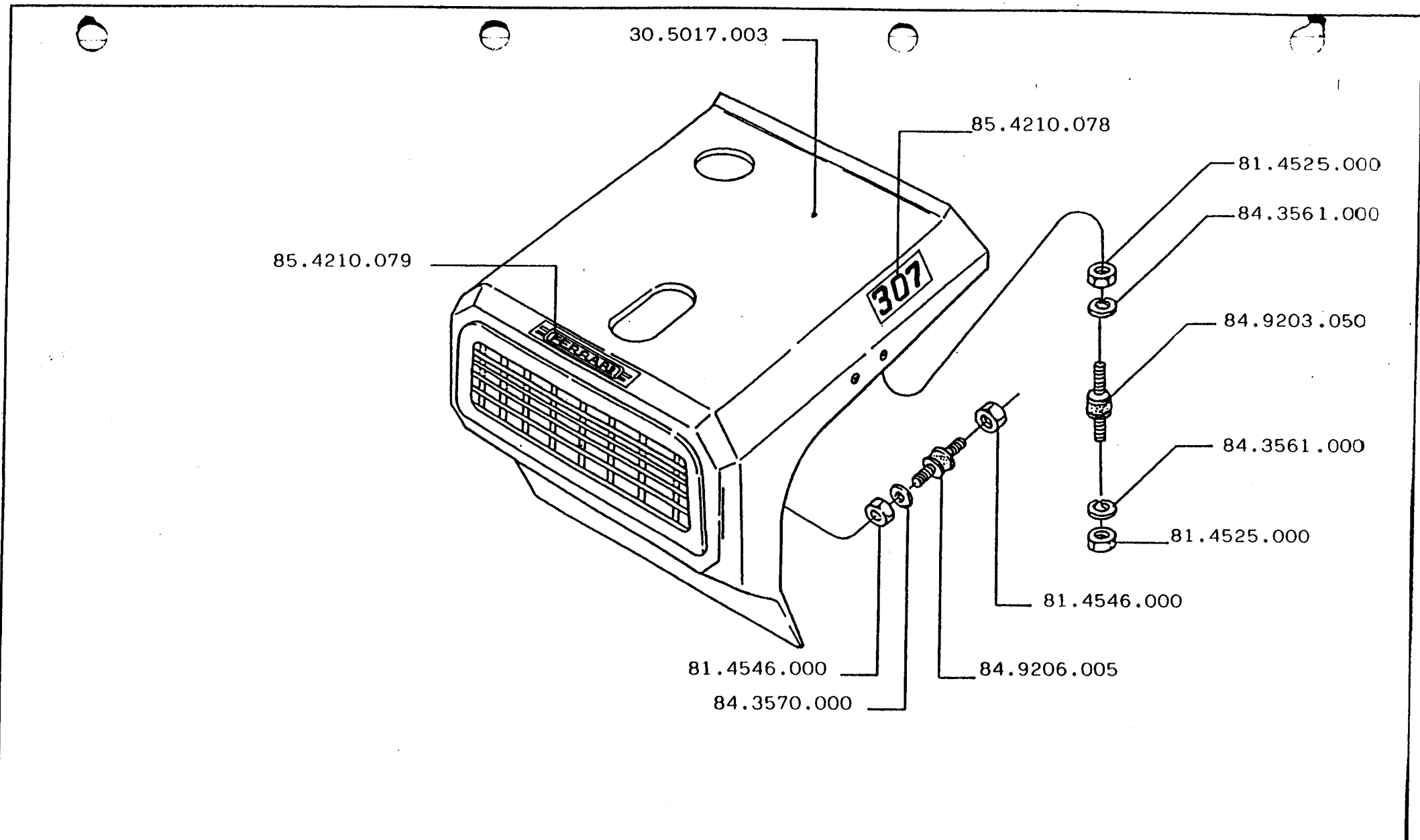

FERRARI

307

COFANO MOTORE 1IM 350
 CAPE MOTOR 1IM 350
 ENGINE 1IM 350 COVER

CAPO MOTOR 1IM 350
 COFFRE MOTEUR 1IM 350
 MOTORHAUBE 1IM 350

PAGINA
03 00
DATA

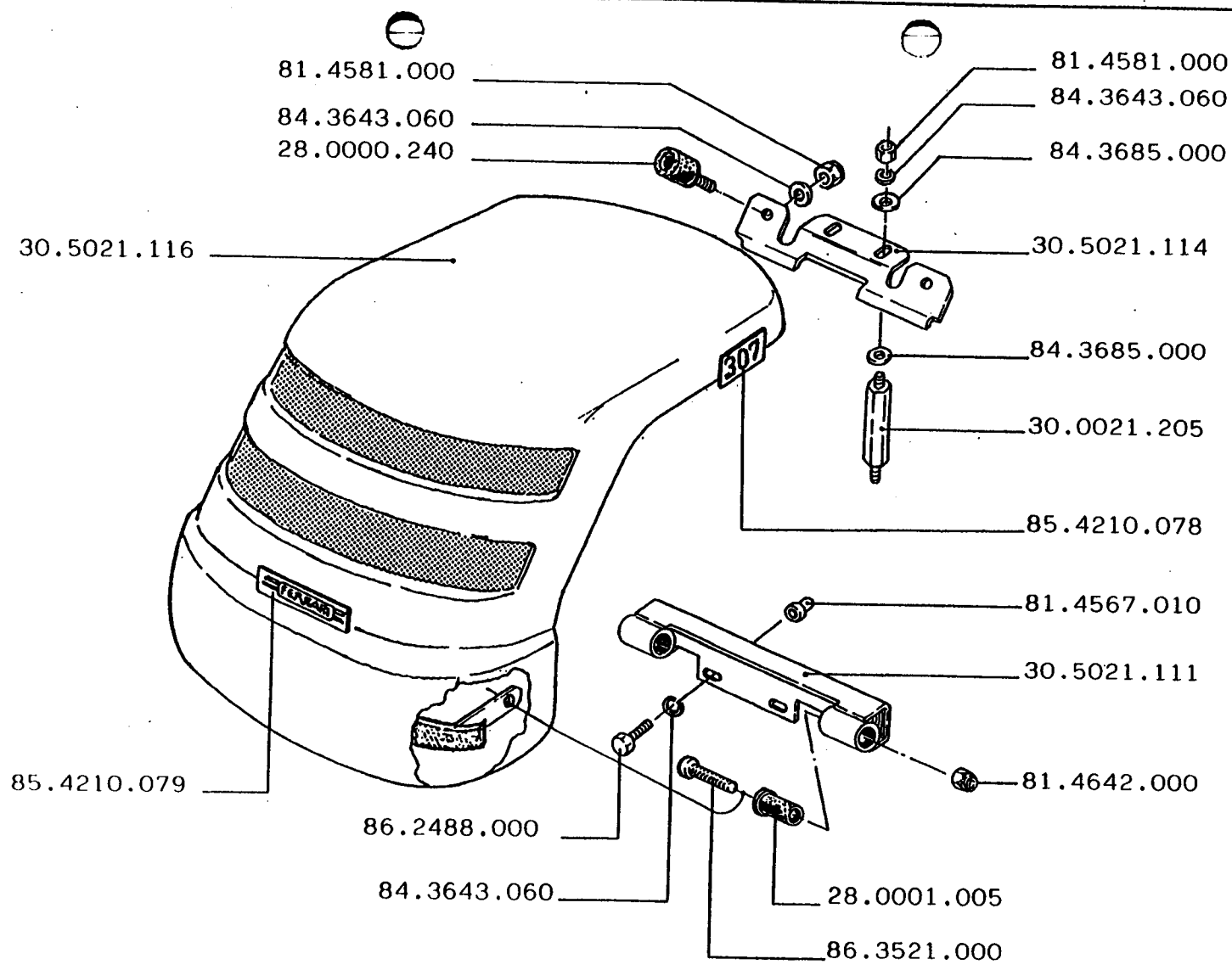

FERRARI

307

COFANO MOTORE 6LD 400
 CAPE MOTOR 6LD 400
 ENGINE 6LD 400 COVER

CAPO MOTOR 6LD 400
 COFFRE MOTEUR 6LD 400
 MOTORHAUBE 6LD 400

PAGINA
04.00
 DATA

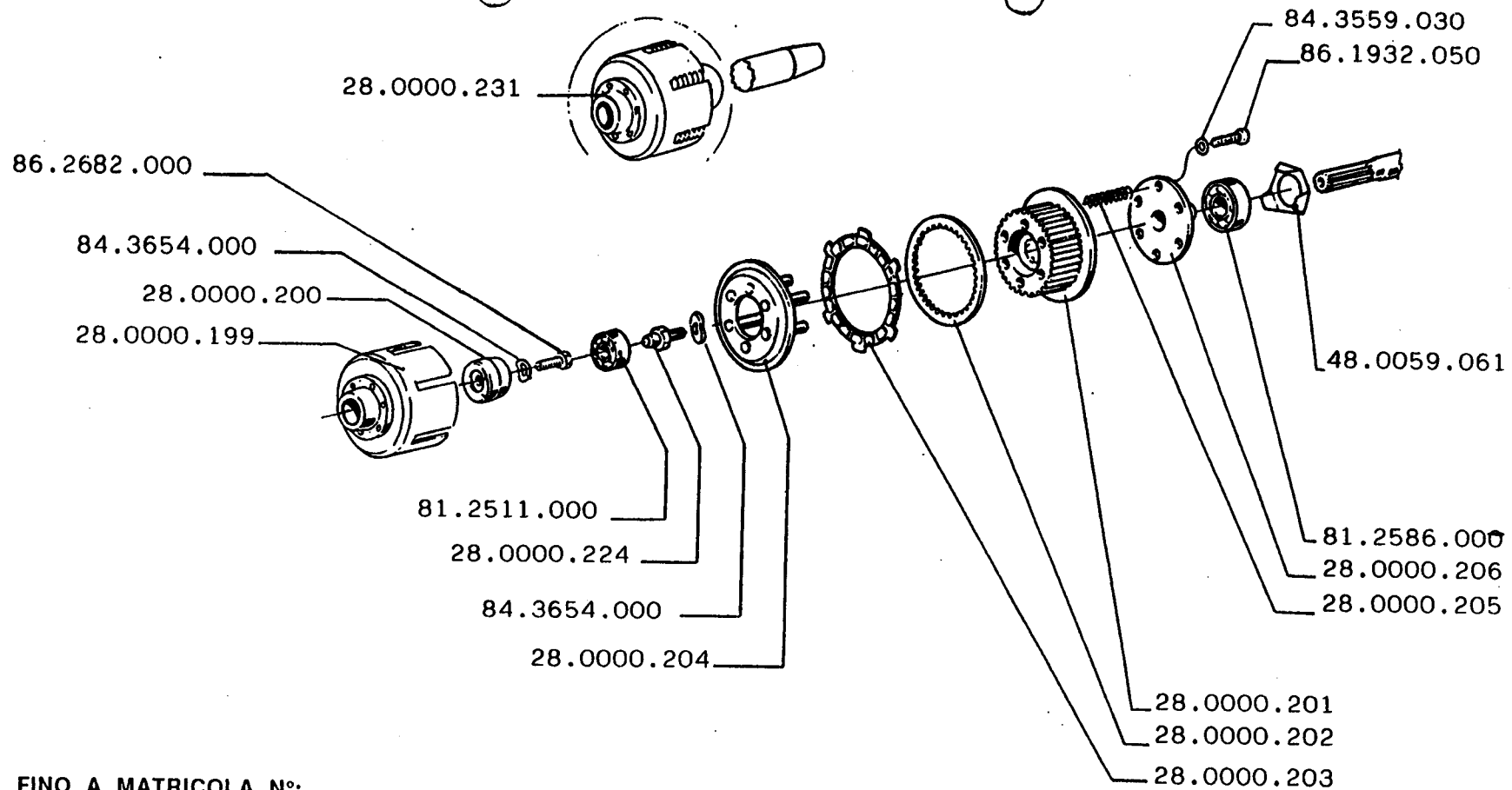

VERSIONE FINO A MATRICOLA N°:

VERSION HASTA LA MATRICULA N°:

VERSÃO ATE' MATRÍCULA N°

VERSION JUSQU'A NR. DE MATRICULE:

VERSION TO SERIAL No.:

AUSFUHRUNG BIS FAHRGESTELL NR.:

282.562

FERRARI

307

FRIZIONE
EMBRAIAGEM
CLUTCH

EMBRAGUE
EMBRAYAGE
KUPPLUNG

PAGINA
05.00
DATA

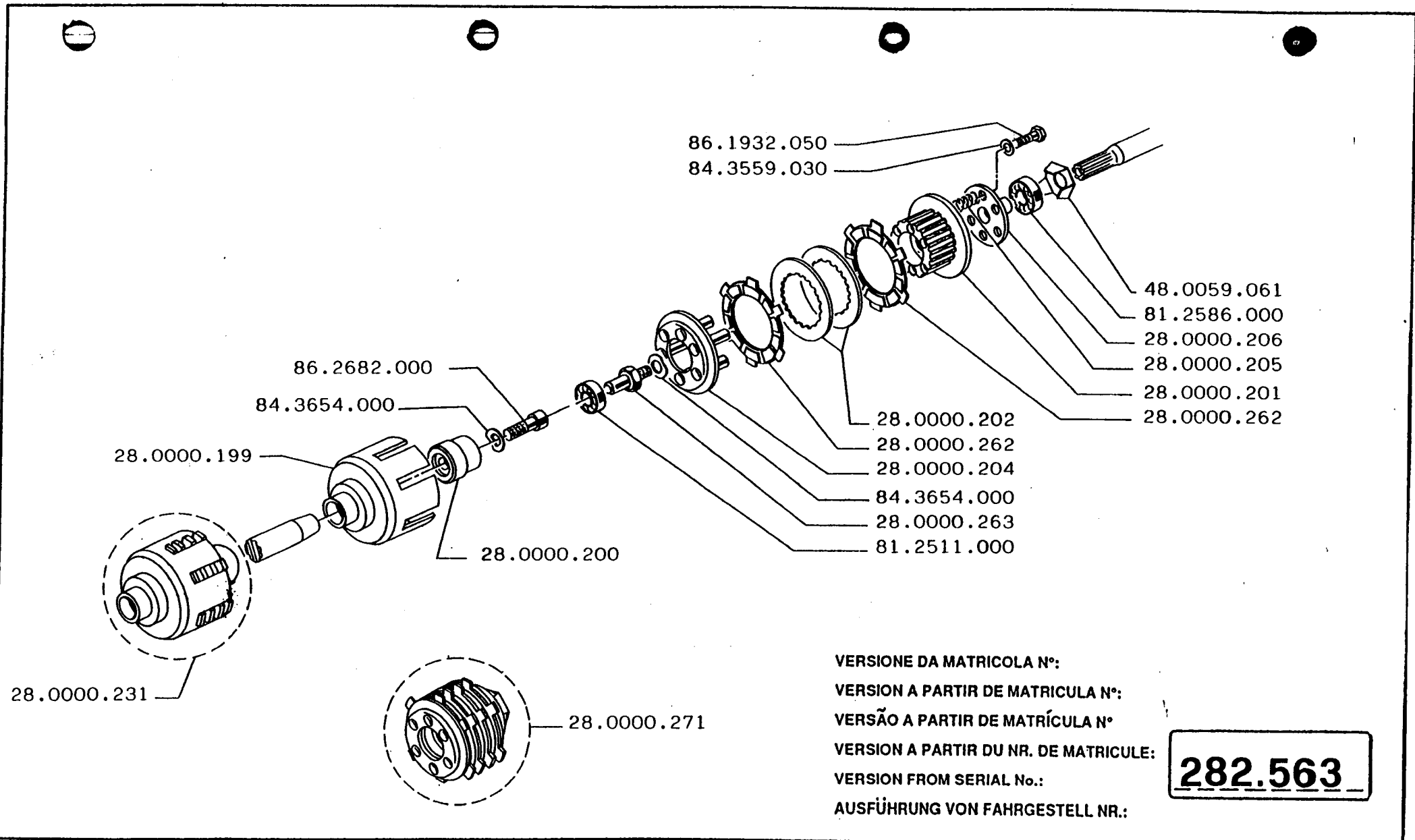

282.563

FERRARI

307

FRIZIONE
EMBRAIAGEM
CLUTCH

EMBRAGUE
EMBAYAGE
KUPPLUNG

PAGINA
05.BIS
DATA

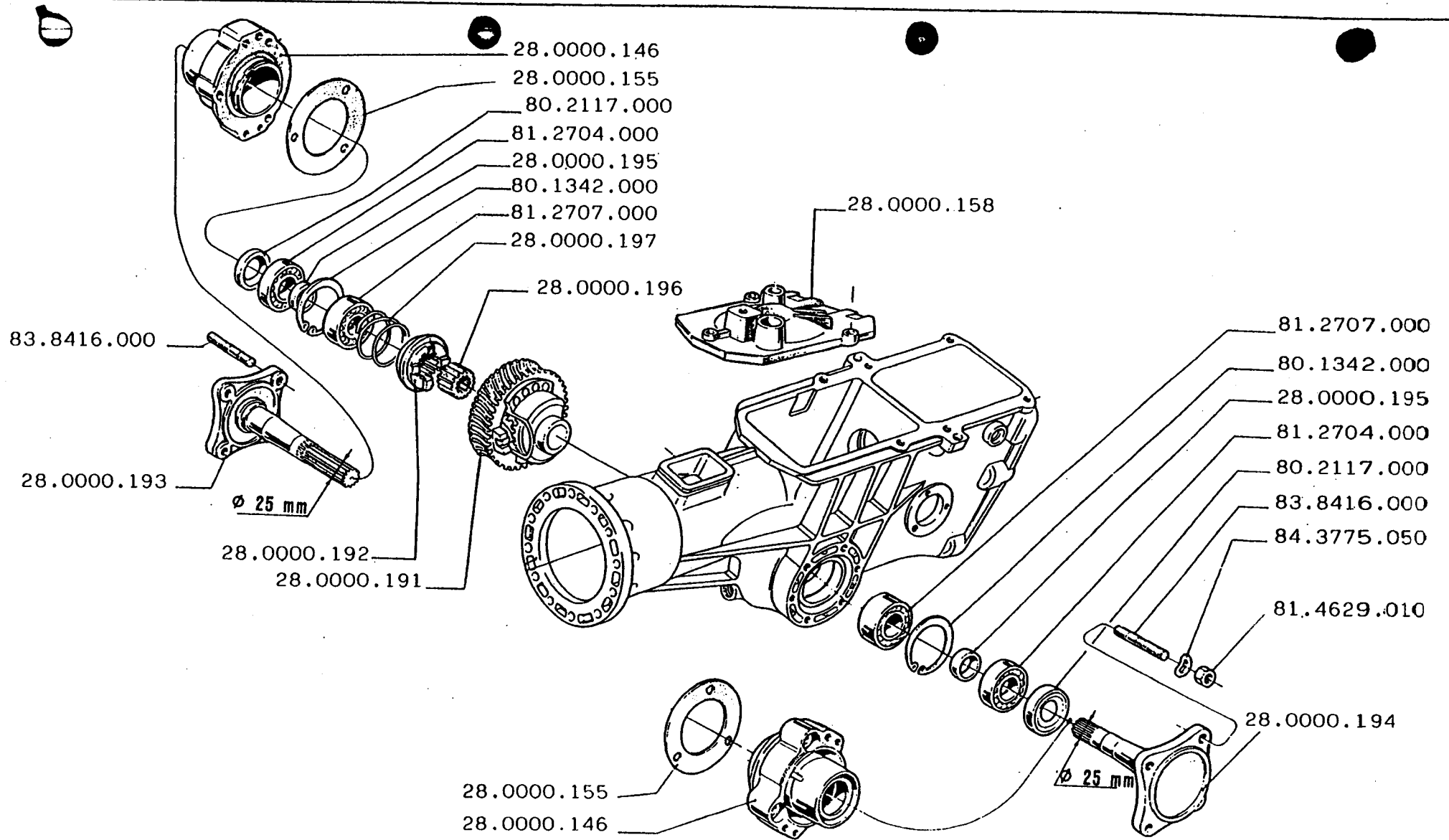

FERRARI

307

DIFFERENZIALE
 DIFERENCIAL
 DIFFERENTIAL

DIFFERENCIAL
 DIFFERENTIEL
 DIFFERENTIAL

PAGINA
 06.00
 DATA

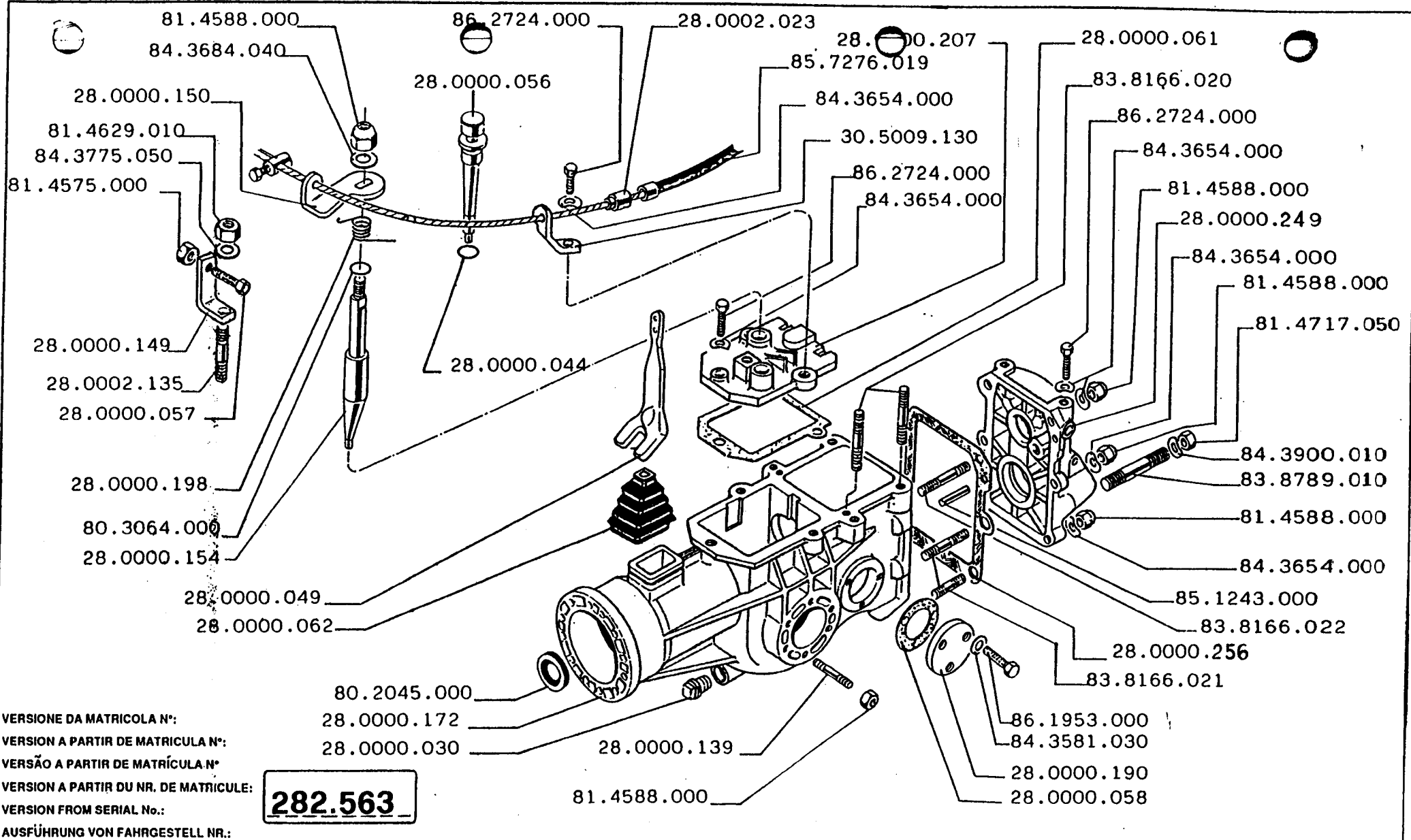

FERRARI

307

SCATOLA CAMBIO
 CAIXA DE VELOCIDADES
 GEARBOX

CAJA DE CAMBIO
 BOITE DE VITESSES
 WECHSELGETRIEBE

PAGINA
07.01
DATA

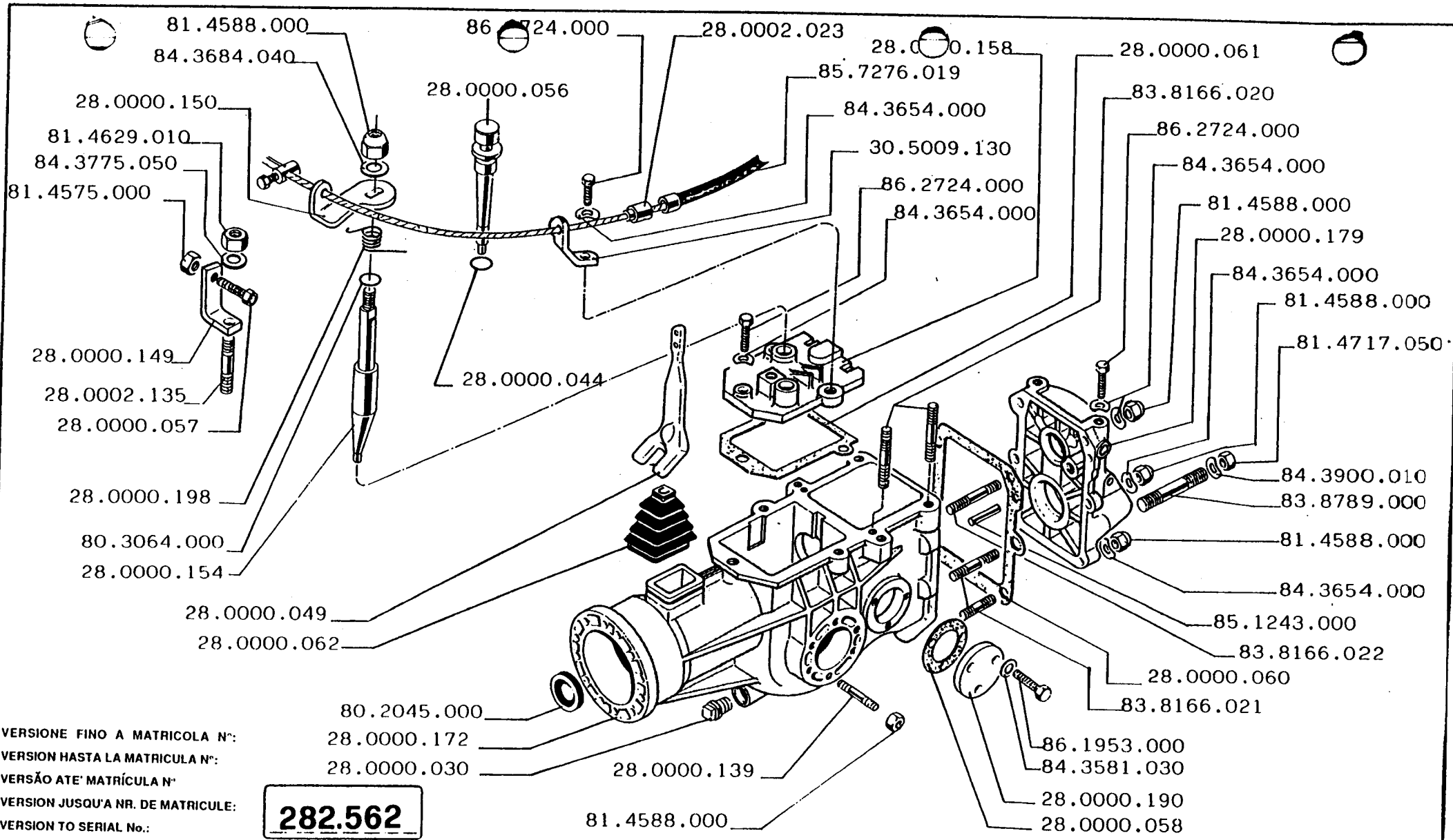

282.562

VERSIONE FINO A MATRICOLA N°:
 VERSION HASTA LA MATRICULA N°:
 VERSÃO ATE' MATRÍCULA N°:
 VERSION JUSQU'A NR. DE MATRICULE:
 VERSION TO SERIAL No.:
 AUSFÜHRUNG BIS FAHRGESTELL NR.:

FERRARI

307

SCATOLA CAMBIO
 CAIXA DE VELOCIDADES
 GEARBOX

CAJA DE CAMBIO
 BOITE DE VITESSES
 WECHSELGETRIEBE

PAGINA
07.00
DATA

VERSIÃO DA MATRÍCULA Nº:
 VERSION A PARTIR DE MATRÍCULA Nº:
 VERSÃO A PARTIR DE MATRÍCULA Nº:
 VERSION A PARTIR DU NR. DE MATRÍCULE:
 VERSION FROM SERIAL No.:
 AUSFÜHRUNG VON FAHRGESTELL NR.:

282.563

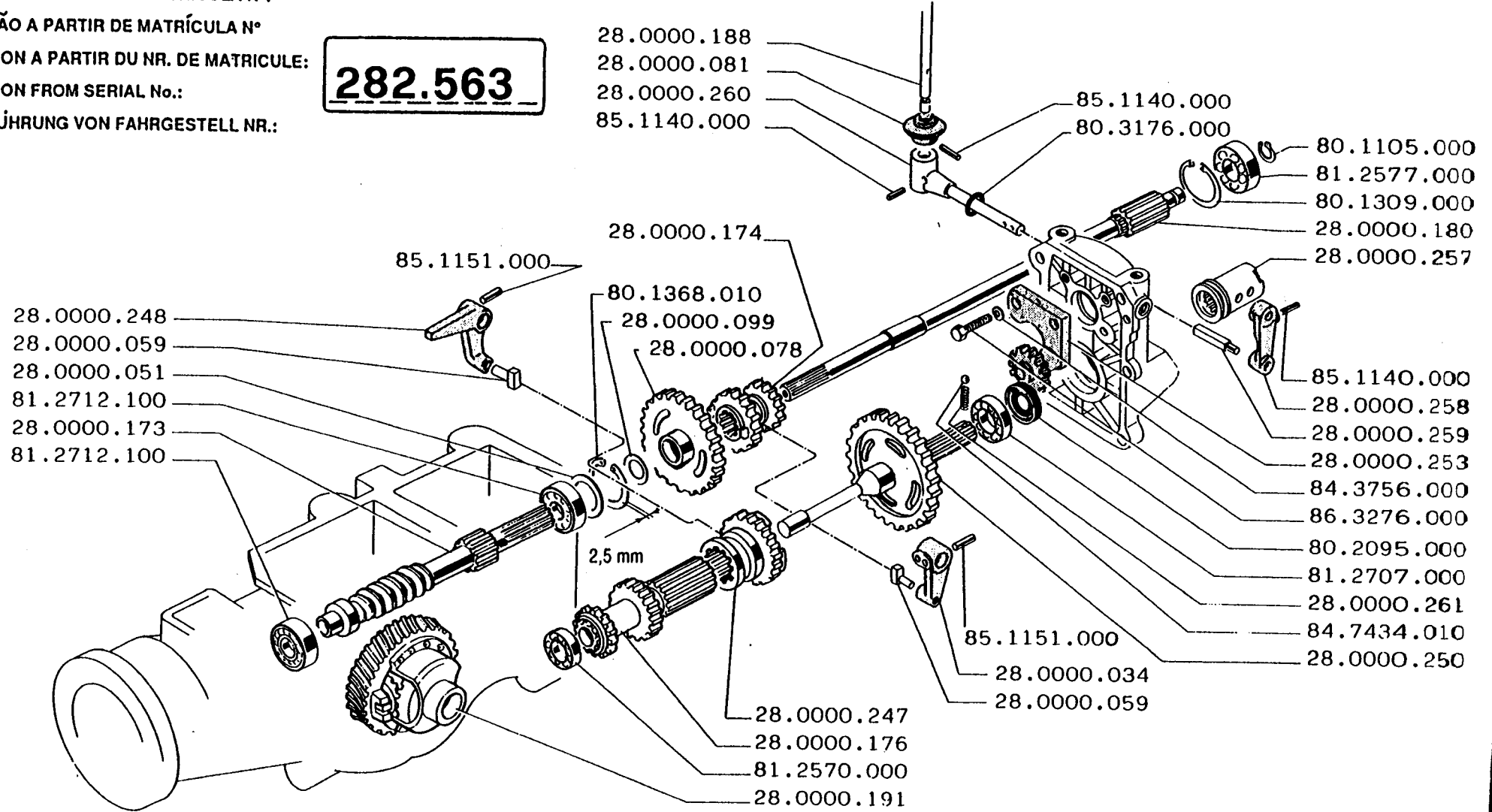

FERRARI

307

INGRANAGGI
 ENGRENAGEM
 GEARS

ENGRANAJES
 ENGRANAGES
 ZAHNRAEDER

PAGINA
08.01
DATA

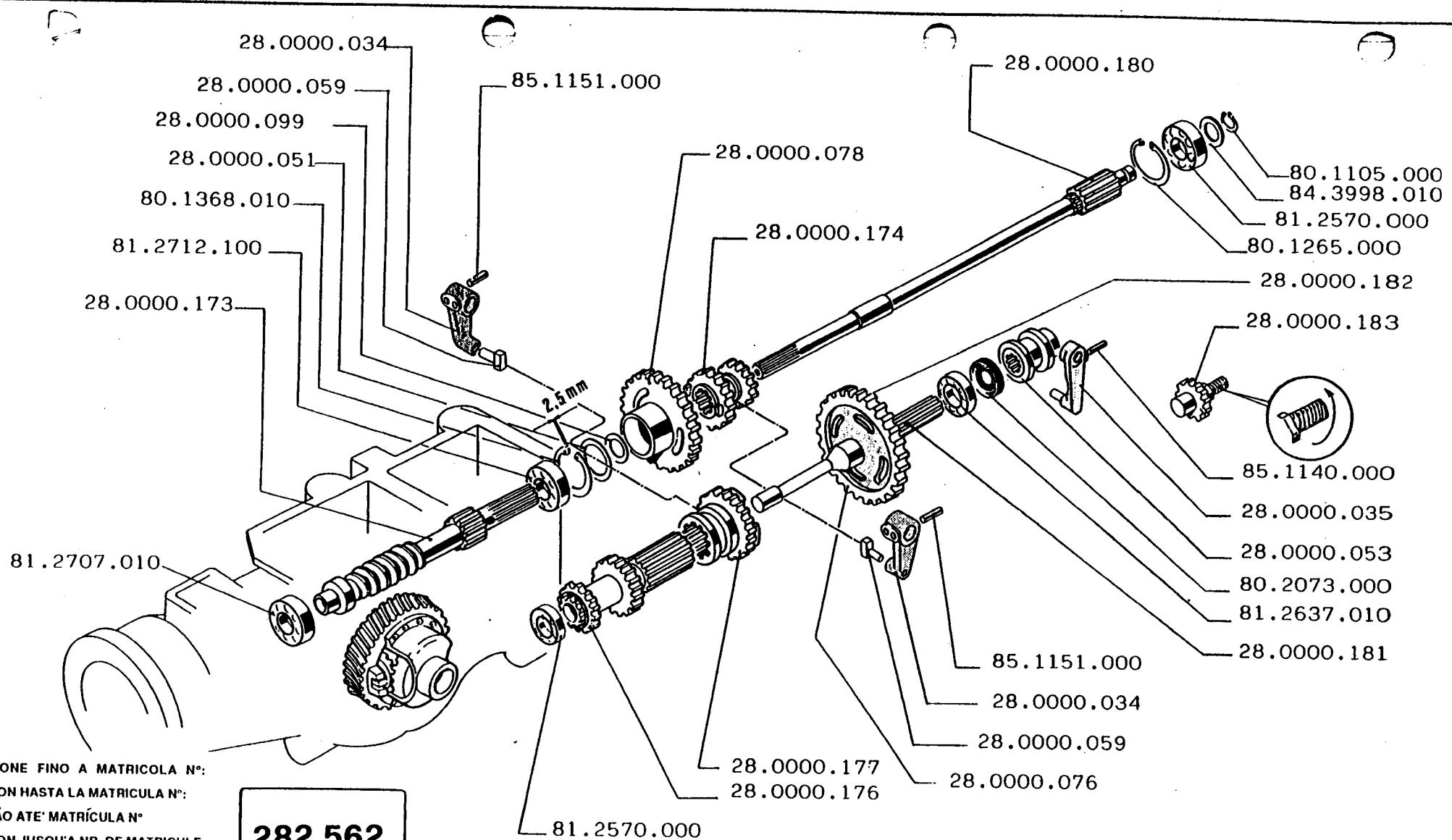

VERSIONE FINO A MATRICOLA N°:
 VERSION HASTA LA MATRICULA N°:
 VERSÃO ATE' MATRÍCULA N°:
 VERSION JUSQU'A NR. DE MATRICULE:
 VERSION TO SERIAL No.:
 AUSFÜHRUNG BIS FAHRGESTELL NR.:

282.562

FERRARI

307

INGRANAGGI
 ENGRENAGEM
 GEARS

ENGRANAJES
 ENGRANAGES
 ZAHNRAEDER

PAGINA
08.00
 DATA

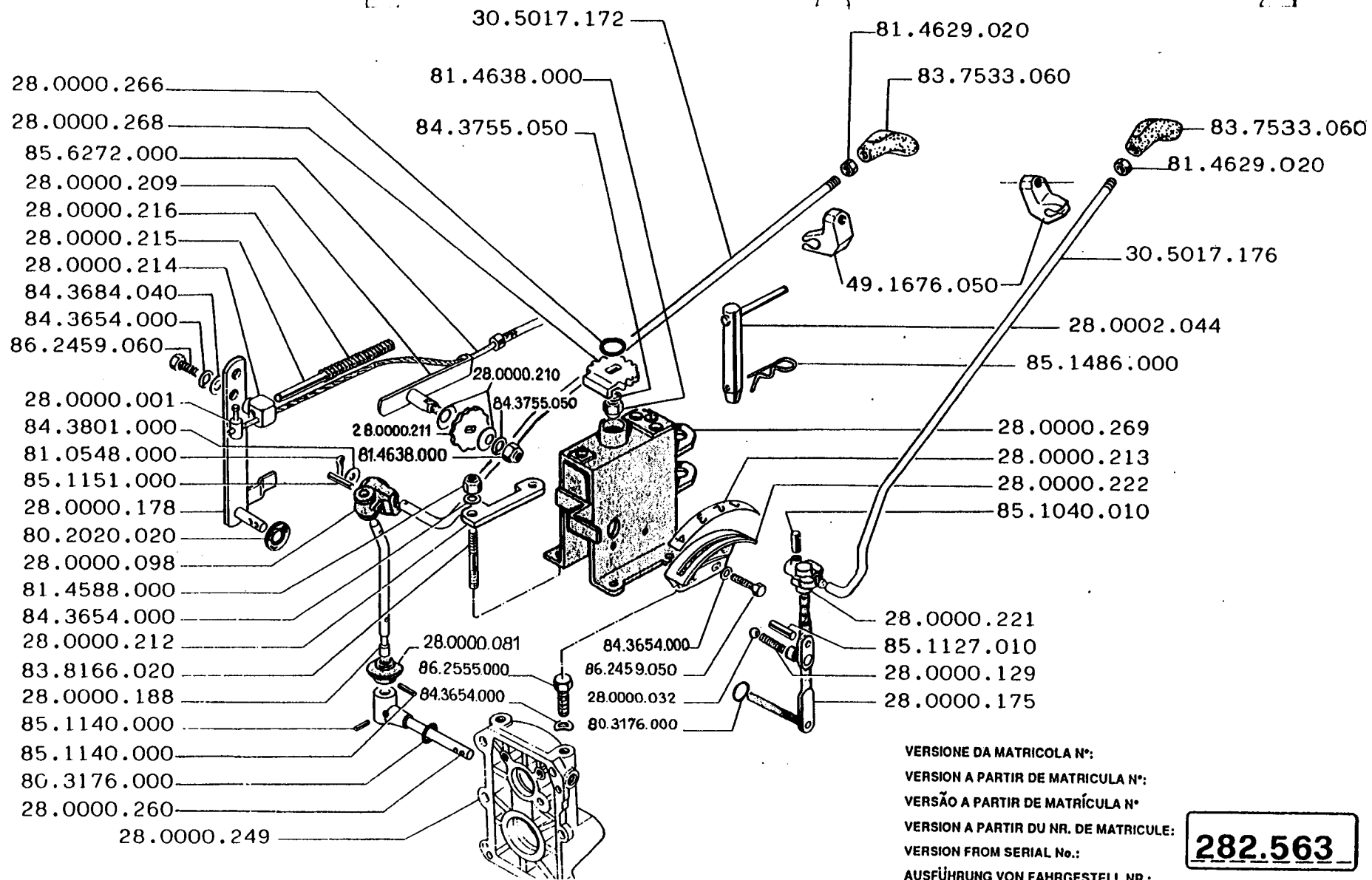

282.563

FERRARI

307

COMANDI
 COMANDOS
 CONTROLS

MANDOS
 COMMANDES
 ANTRIEBE

PAGINA
09.01
DATA

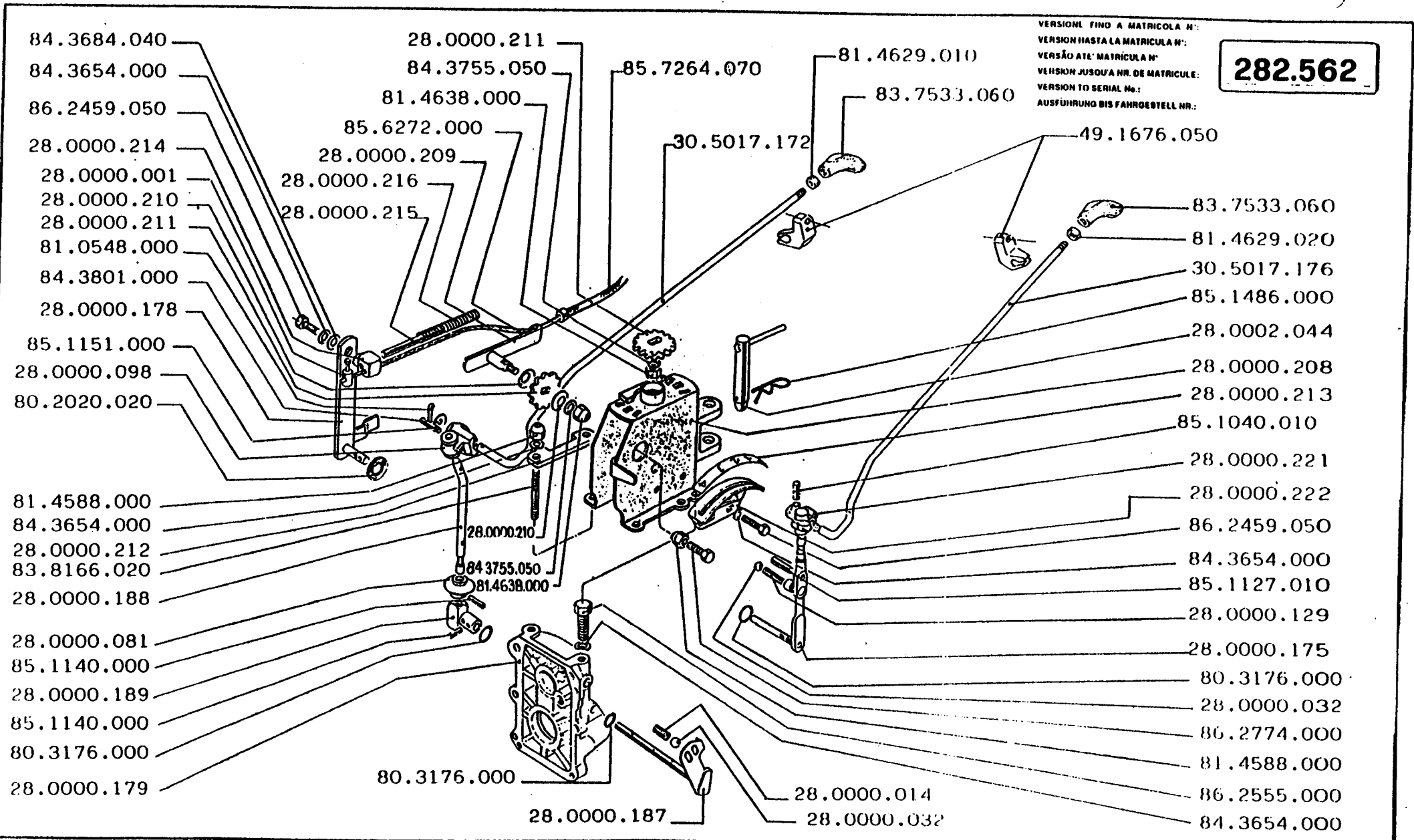

VERSIONI FINO A MATRICOLA N°:
 VERSION HASTA LA MATRICULA N°:
 VERSÃO ATÉ MATRICULA N°:
 VERSION JUSQU'A NR. DE MATRICULE:
 VERSION TO SERIAL No.:
 AUSFÜHRUNG BIS FAHROESTELL NR.:

282.562

FERRARI

307

COMANDI
 COMANDOS
 CONTROLS

MANDOS
 COMMANDES
 ANTRIEBE

PAGINA
09.00
 DATA

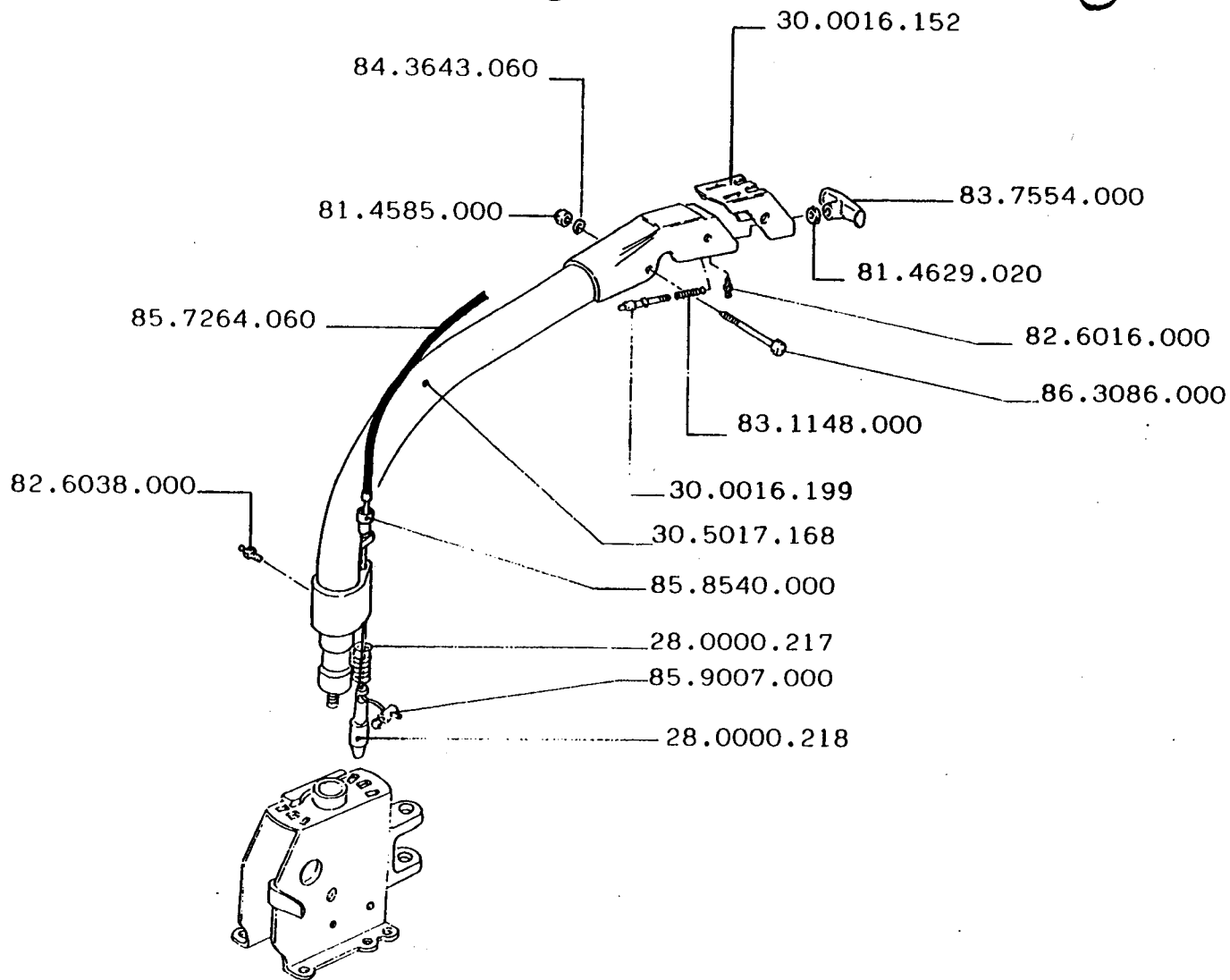

FERRARI

307

PIANTONE
COLUNA
STEERING COLUMN

COLUMNA
PLANTON
LENKSAEULE

PAGINA
10.00
DATA

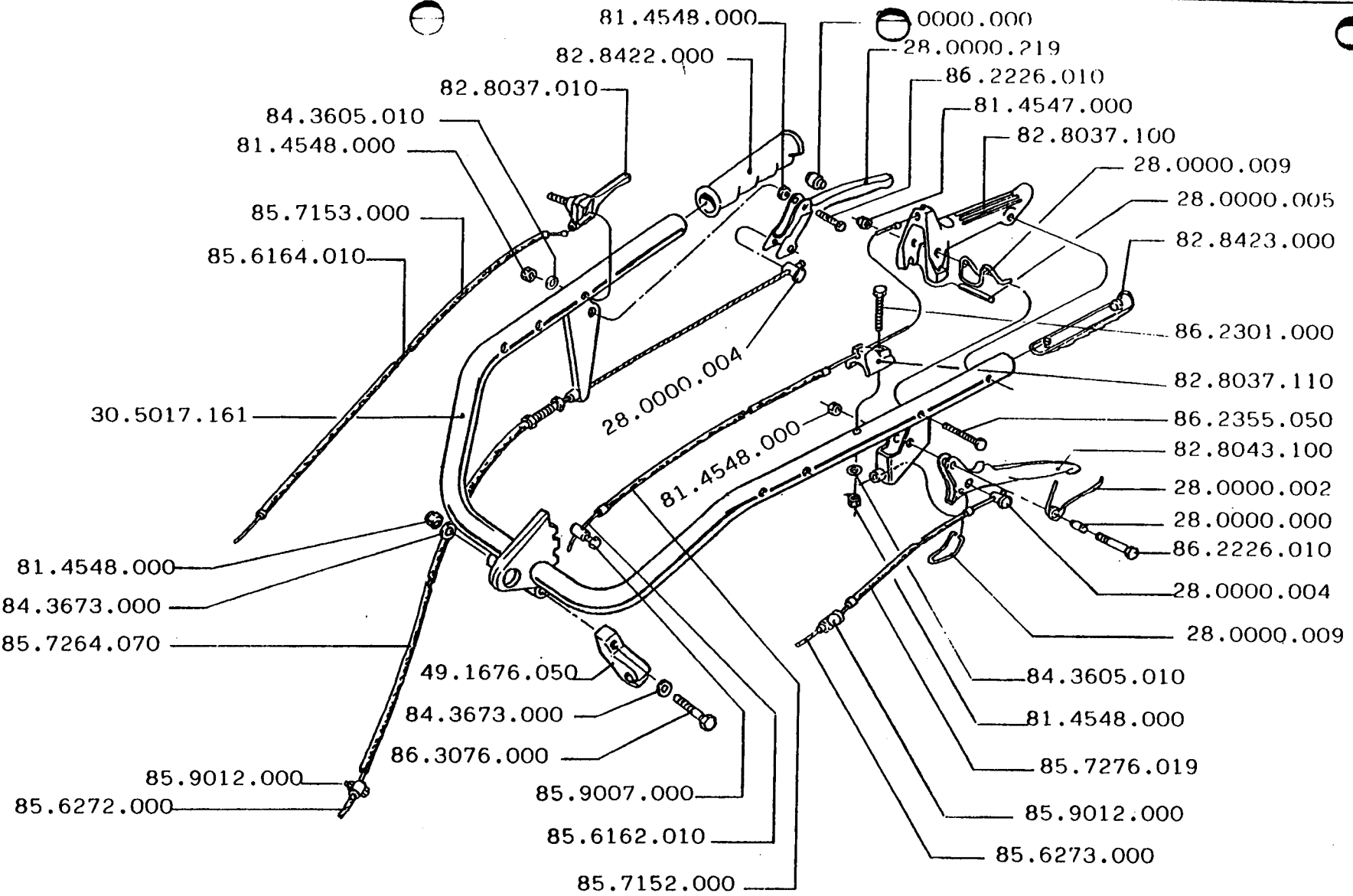

FERRARI

307

MANUBRIO
MANUBRIO
HANDLEBAR

MANILLAR
MANCHERON
LENKER

PAGINA
1100
DATA

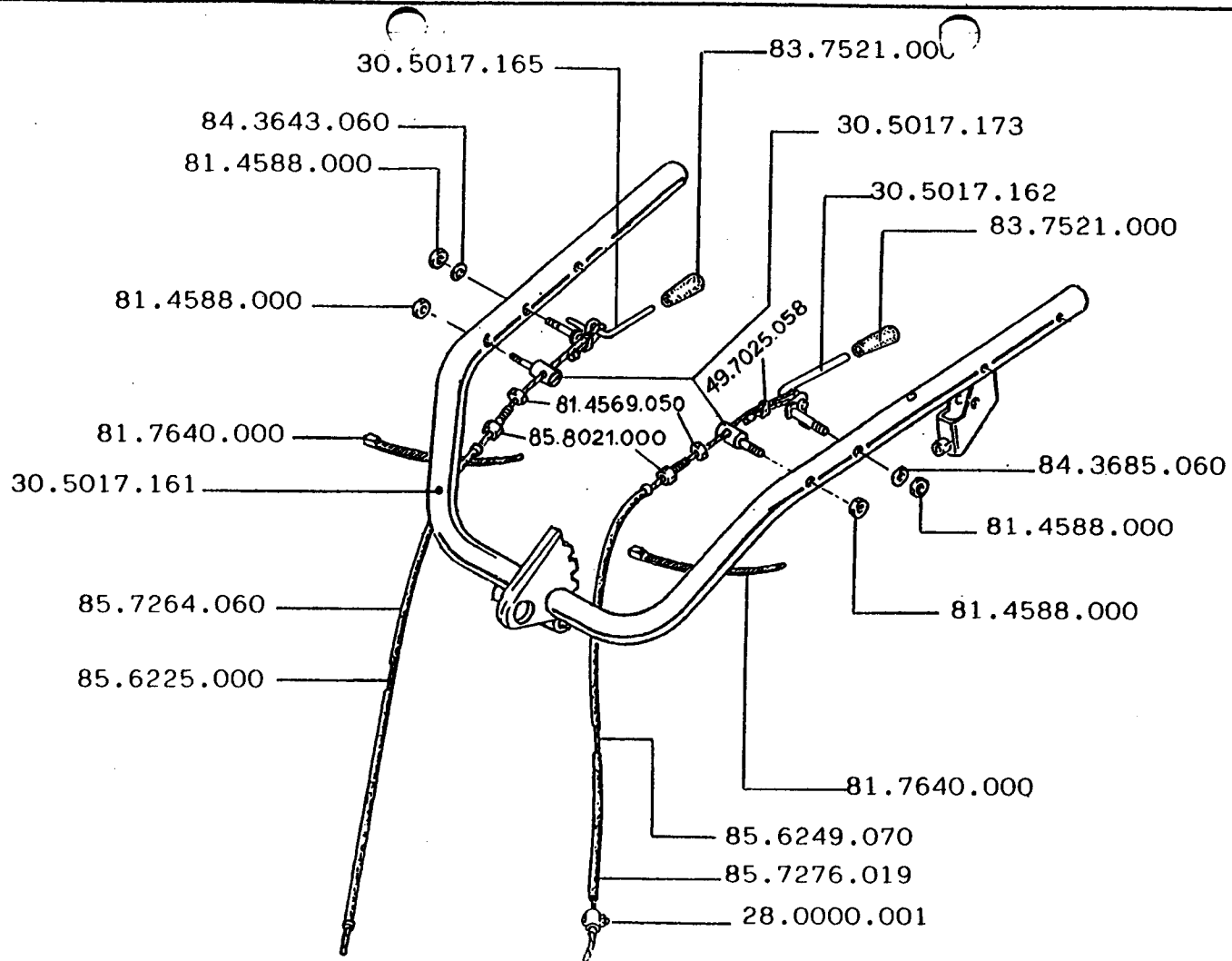

FERRARI

307

MANUBRIO
MANUBRIO
HANDLEBAR

MANILLAR
MANCHERON
LENKER

PAGINA
12.00
DATA

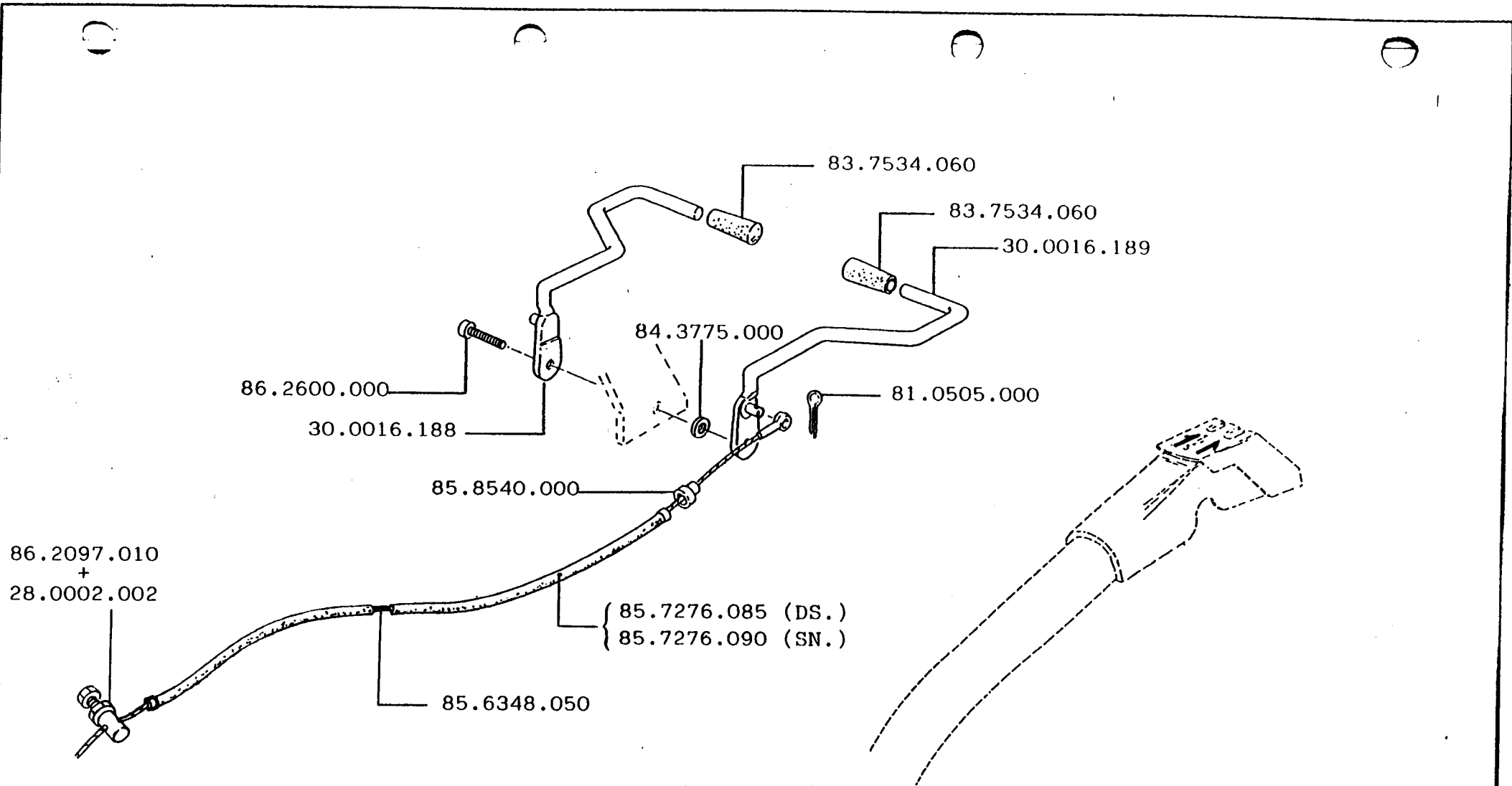

FERRARI

307

COMANDI FRENI
COMANDOS TRAVOES
BRAKES CONTROLS

MANDOS DO FRENOS
COMMANDES FREINS
BREMSSEN ANTRIEBE

PAGINA
13.00
DATA

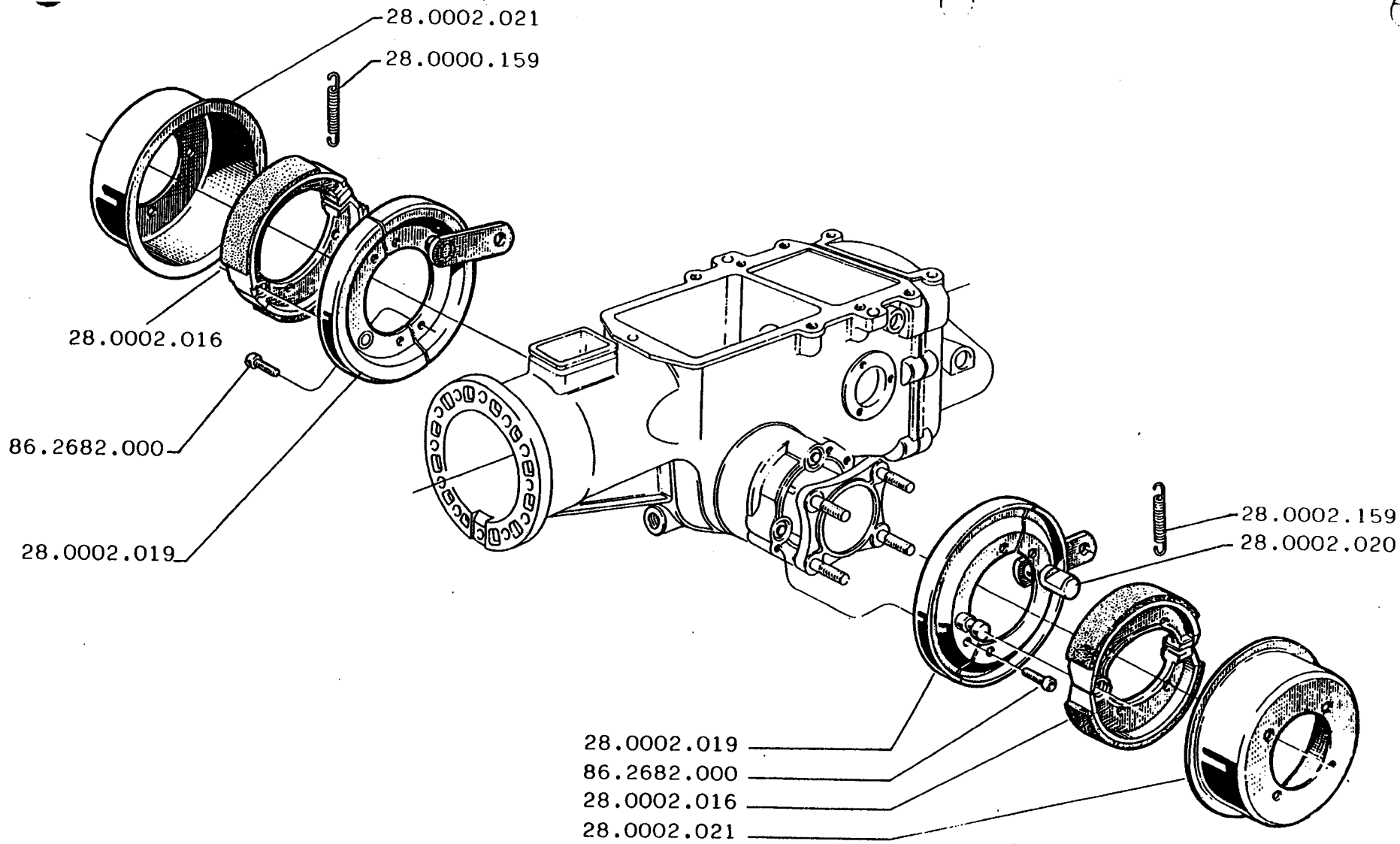

FERRARI

307

**FRENI
TRAVOES
BRAKES**

**FRENOS
FREINS
BREMSEN**

**PAGINA
14.00
DATA**

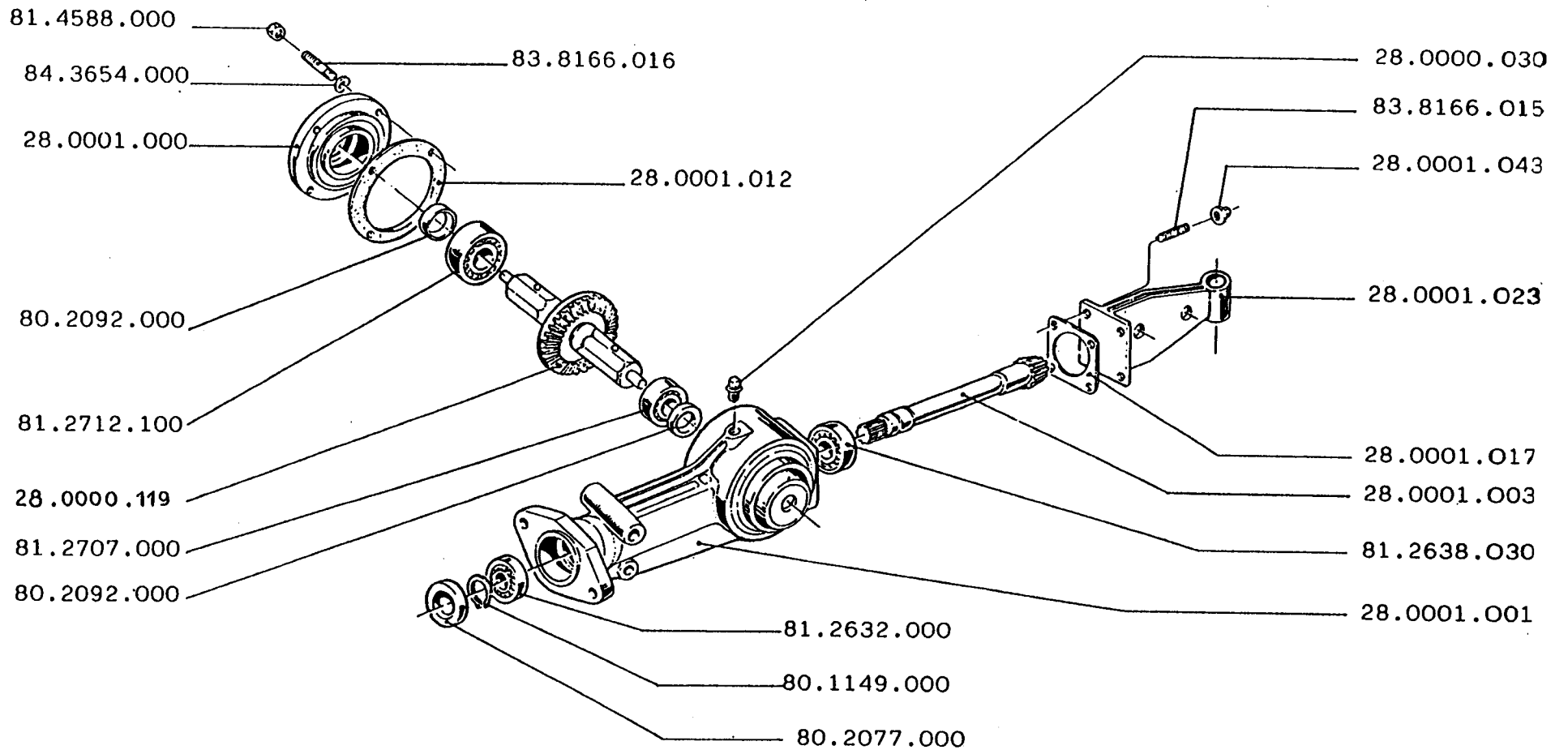

FERRARI

307

FRESA cm.75
 FREZA cm.75
 ROTARY HOE cm.75

FRESADORA cm.75
 FRAISE cm.75
 FRAESER cm.75

PAGINA
15.00
DATA

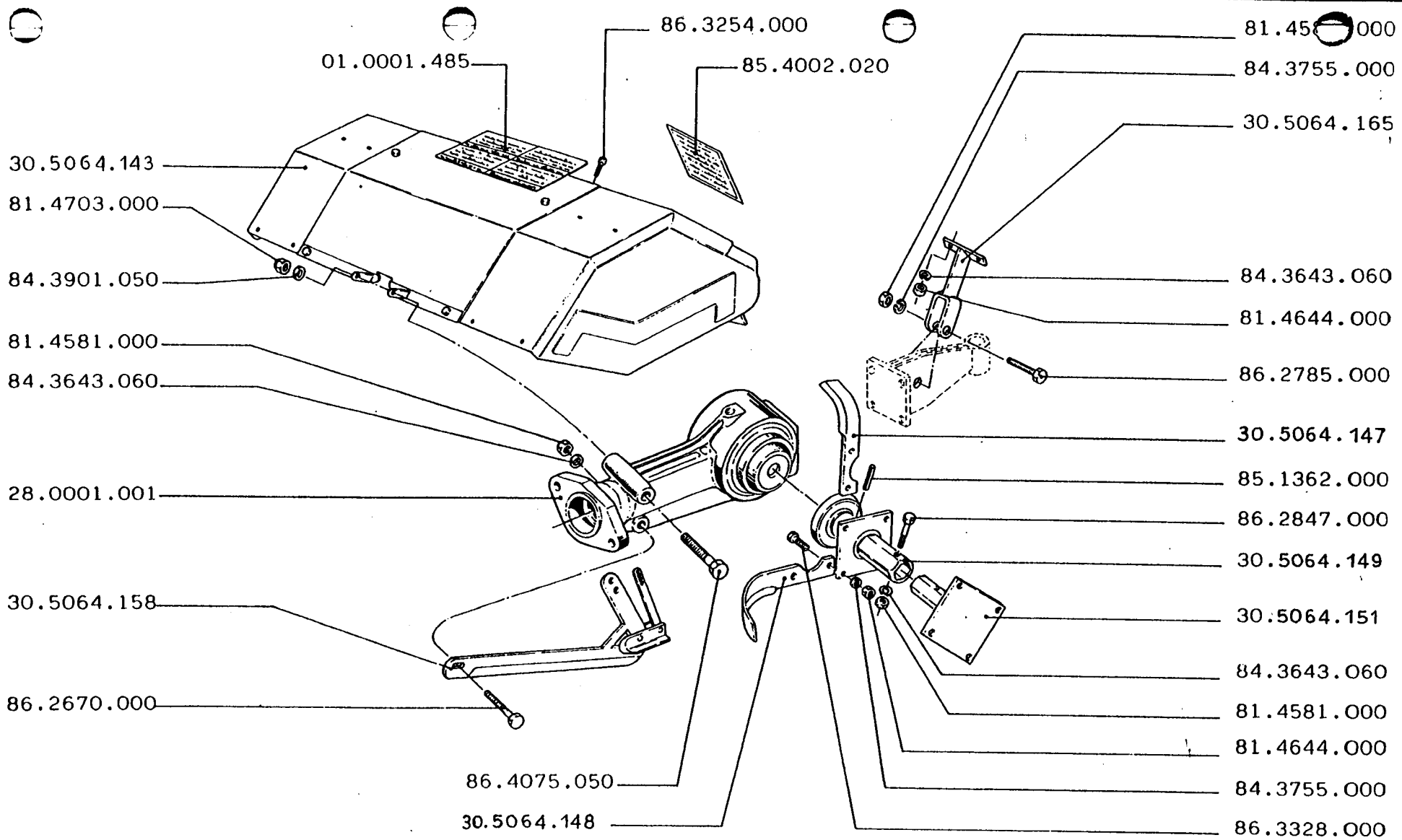

FERRARI

307

FRESA cm.75
 FREZA cm.75
 ROTARY HOE cm.75

FRESADORA cm.75
 FRAISE cm.75
 FRAESER cm.75

PAGINA
16.00
 DATA